

ALUGOME



JAKALUM CONCEPT

MATRA

SYSTÈME COULISSANT À LEVAGE

110 FROIDE





MATRA 110 FROIDE

MATRA 110F

SÉRIE COULISSANTE A LEVAGE

FENÊTRES ET PORTES-FENÊTRES COULISSANT

MATRA 110F est un système coulissant sans rupture de pont thermique aux performances acoustiques et d'étanchéité en réponse aux exigences de la réglementation.



Caractéristiques

- > Système coulissant à levage
- > Alliage d'aluminium EN-AW 6063
- > Assemblage dormant et ouvrant à coupe d'onglet
- > Joints d'étanchéité en EPDM
- > Verrouillage multipoints avec poignée
- > Epaisseur moyenne : 1,5 mm
- > Epaisseur du vitrage : jusqu'à 28 mm
- > Ossature du dormant (2rails) : 110 mm
- > Ossature du dormant (3rails) : 167mm
- > Section visible de l'ouvrant : 52 mm

Performances du système

Performances AEV :

Air	Eau	Vent
A3	E7A	V5C

POIDS MAXIMAL PAR VANTAIL

300 Kg

DIMENSIONS MAXIMALES PAR VANTAIL

110 à levage : (1600 x 2800) mm

PERFORMANCES THERMIQUES

(AVEC 4/12/4) : UW EN W/ (M²K).

1238 x 1480 mm : 4.2 W/(m²K)

1480 x 2180 mm : 4.05 W/(m²K)

COUPES : SOLUTION FROIDE

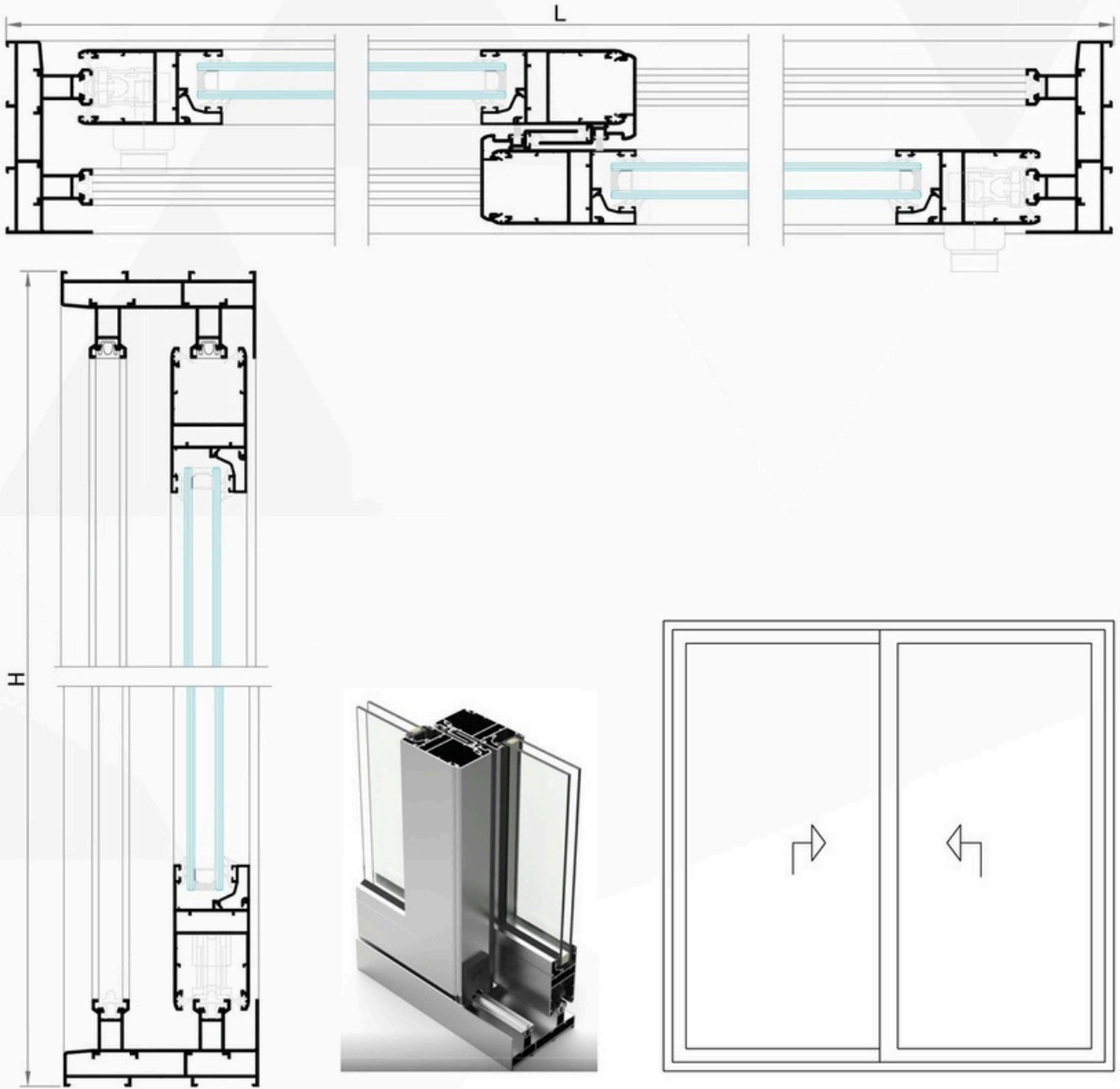

POSSIBILITES D'ASSEMBLAGE

Coulissant 2 vantaux, 2 rails

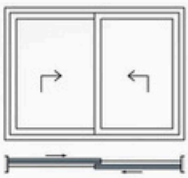

Couli-fixe

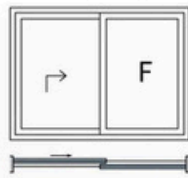

Coulissant à levage 3 vantaux, 2 rails

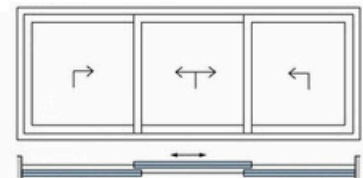

Coulissant à levage 3 vantaux, 3 rails

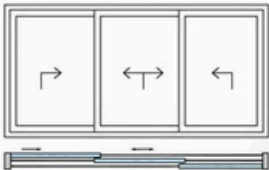

Couli-fixe 2 vantaux, 2 fixes

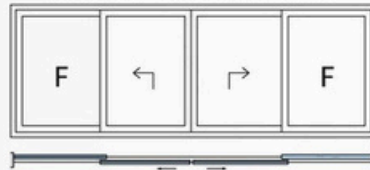

Coulissant à levage 4 vantaux, 2 rails

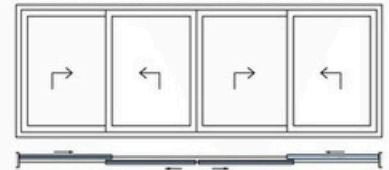

Coulissant à levage 6 vantaux, 3 rails











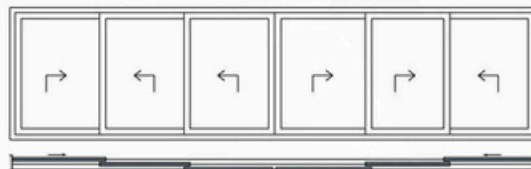

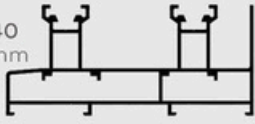

TABLEAU GÉNÉRAL DES PROFILÉS ET INERTIES

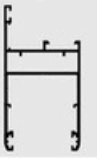
Profilsés		Inertie (cm ⁴)		Profilsés		Inertie (cm ⁴)	
		lx	ly			lx	ly
Réf. 8964/640 Dormant 110mm 2rails		15.52	88.54	Réf.8207/640 Parclose			
Réf. 21015/640 Complément Dormant 03 Rails		7.41	10.16	Réf.8485/640 Parclose			
Réf. 8951/640 Ouvrant périmétral		18.15	13.05	Réf.8630/640 Couvre joint 50 mm			
Réf. 8952/640 Chicane MATRA		5.35	5.98	Réf.2850/650 Couvre joint 45 mm			
Réf. 8962M/640 Profil de jonction		4.76	2.28	Réf.2877/650 Couvre joint droit 45mm			
Réf.4958/NTR/640 Complément Profil de Jonction							
Réf.895401/ANN/640 Rail anodisé naturel							
Réf. PL600.42 Renfort		16.10	5.31				

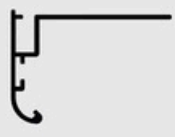
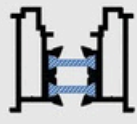
SECTION DES PROFILES

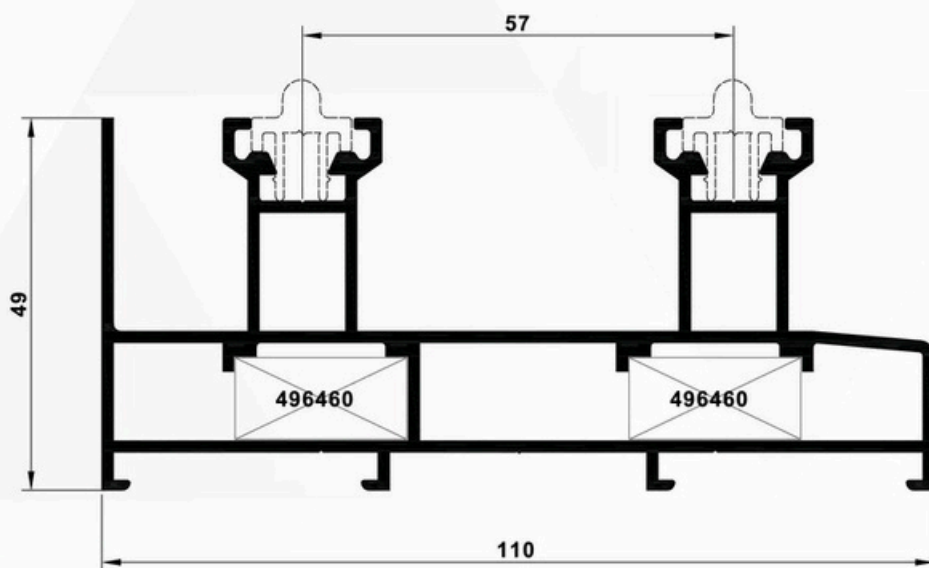

Réf. 8964/640
Dormant 110 mm 2 rails

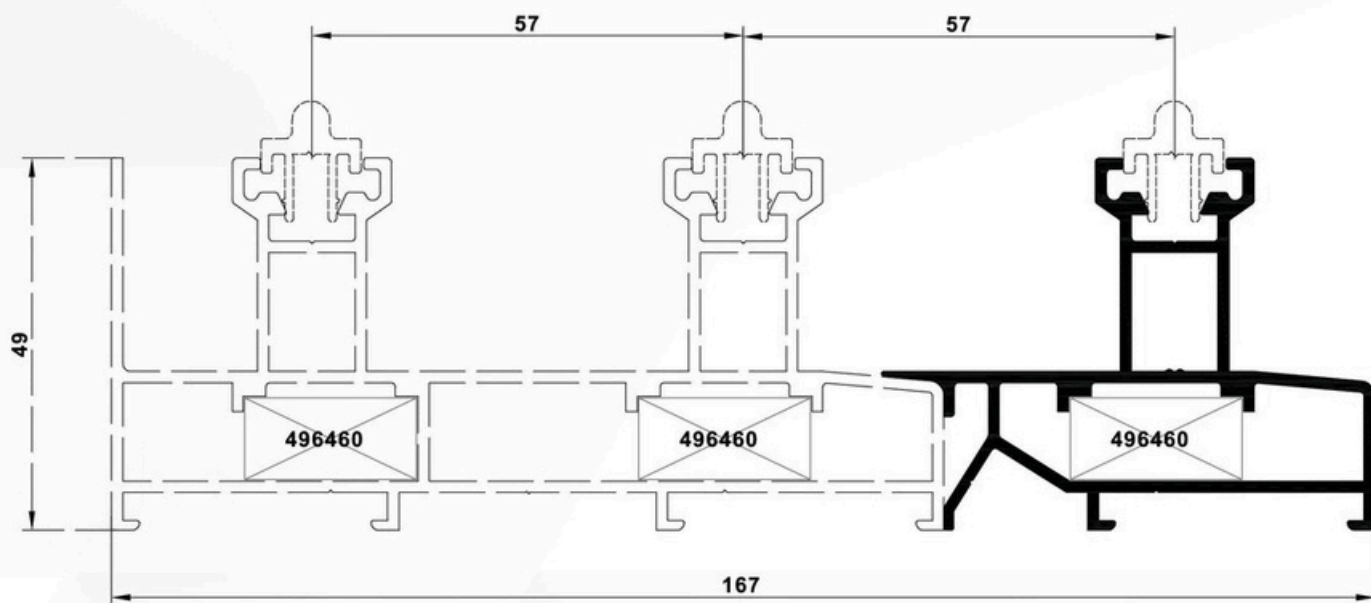

Réf. 21015/640
Complément Dormant 03 Rails

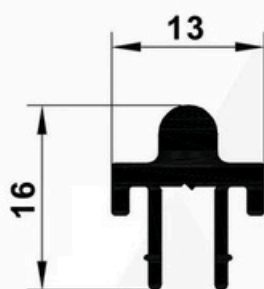

Réf. 895401/ANN/640
Rail anodisé naturel

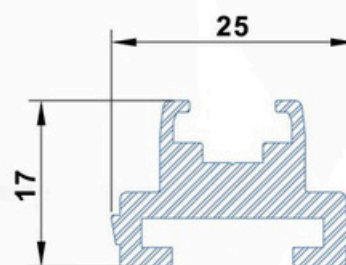

Réf. 4958/NTR/640
Complément Profil de Jonction

SECTION DES PROFILES

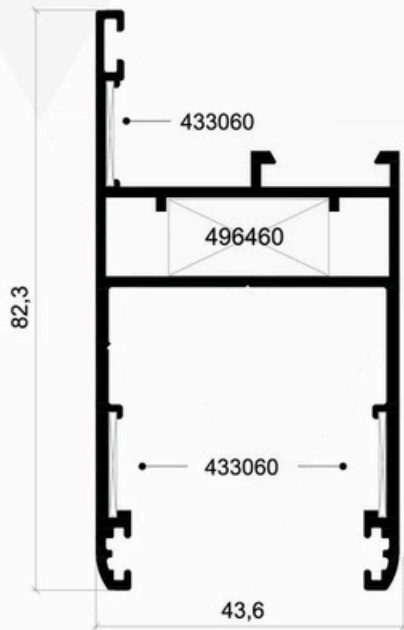

Réf. 8951/640
Ouvrant périmétral

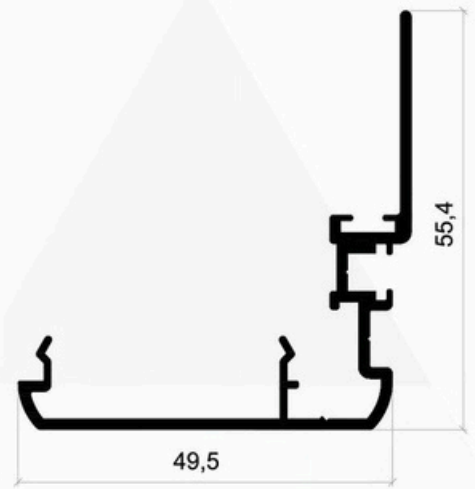

Réf. 8952/640
Chicane

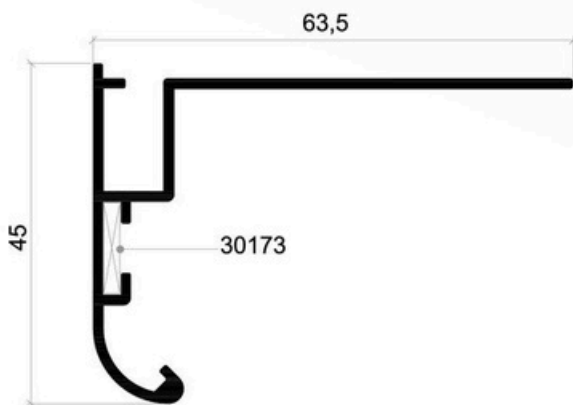

Réf. 2850/650
Couvre joint arrondi 45 mm

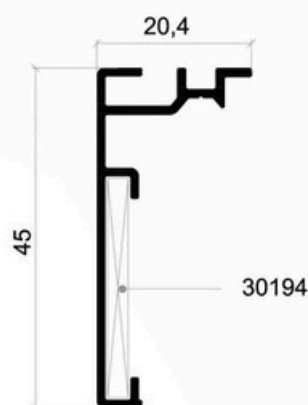

Réf. 2877/650
Couvre joint droit 45mm

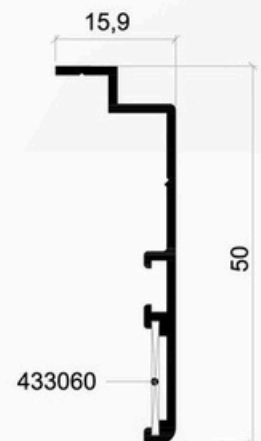

Réf. 8630/640
Couvre joint 50mm

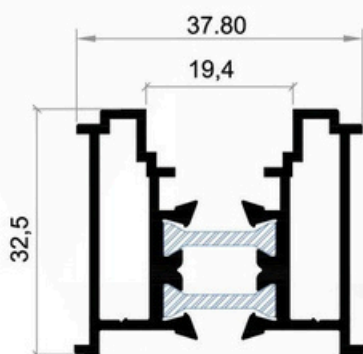

Réf. 8962M/640
Profil de Jonction

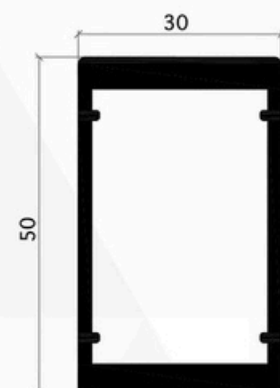

Réf. PL600.42
Renfort



JOINTS & ACCESSOIRES

PARCLOSES

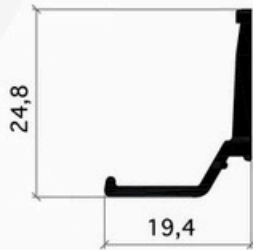

Réf. 8485/640
Parclose

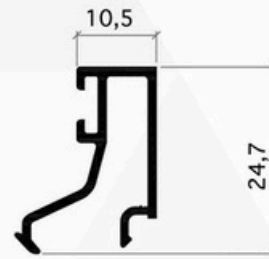

Réf. 8207/640
Parclose

Épaisseur vitrage	Parclose	Vitrage	
		Joint extérieur	Joint intérieur
12	8207/640	5104	Cuna12NH
14	8207/640	5104	Cuna8NH
16	8207/640	5104	Cuna6NH
18	8207/640	5104	Cuna5NH
20	8485/640	5104	Cuna12NH
22	8485/640	5104	Cuna8NH
24	8485/640	5104	Cuna6NH
26	8485/640	5104	Cuna5NH
28	8485/640	5104	Cuna3N

Référence	Désignation	Schéma
405660	Joint chicane	
495060	Joint d'étanchéité	
495160	Joint dormant	
497360	Joint brosse 7*10	

Joint Intérieur		
Référence	Épaisseur	Schéma
Cuna2N	2-2,5 mm	
Cuna3N	3-3,5 mm	
Cuna4N	4-5 mm	
Cuna5NH	5-6 mm	
Cuna6NH	6-7 mm	
Cuna8NH	8-9 mm	
Cuna10NH	9-10 mm	
Cuna12NH	11-12 mm	

Joint extérieur	
Référence	Schéma
5104	

ACCESSOIRES

Réf.
403960
Equerre d'alignement
ouvrant



Réf.
2316
Poignée à levage avec Cuvette



Réf.
433060
Equerre d'alignement
ouvrant



Réf.
ST2100
Chariots de levage 200Kg



Réf.
496460
Equerre d'Assemblage



Réf.
ST2200
Chariots intermédiaires
300Kg



Réf.
497660
Étanchéité Central



Réf.
234302
Kit points de fermeture



Réf.
495360
Kit Montant central



Réf.
234303
Kit vantail intermédiaire



Réf.
496560
Câle Chariot



Réf.
A235313
Kit de câles



Réf.
497460
Guide
supérieur/inférieur



Réf.
496360
Guide vantail



ACCESSOIRES

Réf.
233504
Chariot fixe



Réf.
ST32704
Ressort auxiliaire



Réf.
233011
Barre d'union 1760 mm



Réf.
234322
Gâche horizontale



Réf.
C234502
Multipoint 2400 mm



Réf.
STAC32720
Butée fin de course



Réf.
C234503
Multipoint 2700 mm



Réf.
BR_3918
Bouchon renfort



Réf.
ST2400
Multipoint 2700 mm avec rallonge



Réf.
4962
Matrice MATRA









ULYSSE PÉRIMÉTRALE



80



ROCK

URDE





JAKALUM CONCEPT



EMAIL : jakalumconcept@gmail.com

TÉL : +212 663-281848

+212 663-846150

+212 663-281848

SHOWROOM : 143 lot hadj fatah casablanca



<https://jakalum.ma>



Jakalum Concept



Jakalum.Concept